

So, You Want

A

Volunteer...



VACAVILLE POLICE DEPARTMENT

A Handbook for Supervisors of *“Volunteers In Police Service”*

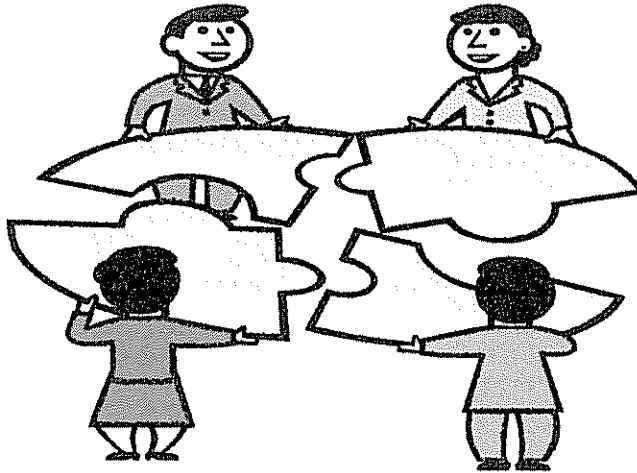

INTRODUCTION

Volunteers have been helping the Vacaville Police Department for over twenty years and most staff would say they could not manage without them. Because of the vital role volunteers hold within the Department a full time employee was hired in 2000 to coordinate the program. Volunteers have a lot to offer; they can do many things you may not have the time or skill to do yourself. However, volunteers are not “free.” They require an investment of your time, thought, and energy, but the payoff can be tremendous. This booklet is designed to help answer some of the questions you may have about working with volunteers.

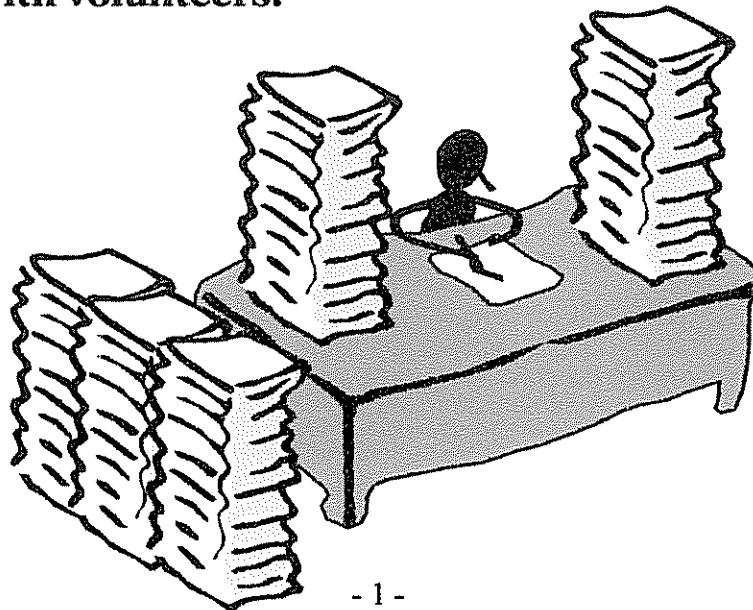

WHO VOLUNTEERS AND WHY?

Volunteers are people just like you and me. They have widely varying backgrounds and interests and they volunteer for many different reasons:

To gain job experience and references

To learn new skills

To explore new careers

To be with other people

To help others

To work for a better community

To feel useful

Take the time to find out what motivates your volunteer. Volunteers whose needs are met are happier and more likely to volunteer longer.

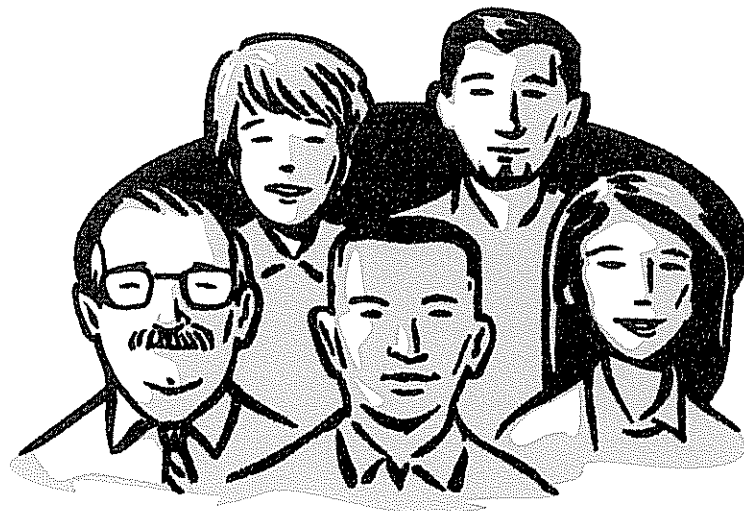

HOW DO I GET A VOLUNTEER?

When you need that extra help on a regular basis:

Complete a Request for Volunteer Service form. Volunteers want information about a job before they commit their time and energy. It helps ensure that the proper individual is recruited for your job. Consult with the Volunteer Coordinator when you need assistance.

Submit your request to the Volunteer Coordinator, who will then begin recruiting volunteers for your position.

For added success, take advantage of opportunities that arise to handpick a new recruit, such as joining the interview panel.

When you need assistance for a short-term, temporary assignment:

Contact the Volunteer Section Office to discuss your particular needs and outline the nature of the assignment.

Request for Volunteer Service forms are available online at chpolice on 'nt2' (I:) drive in the volunteer file.

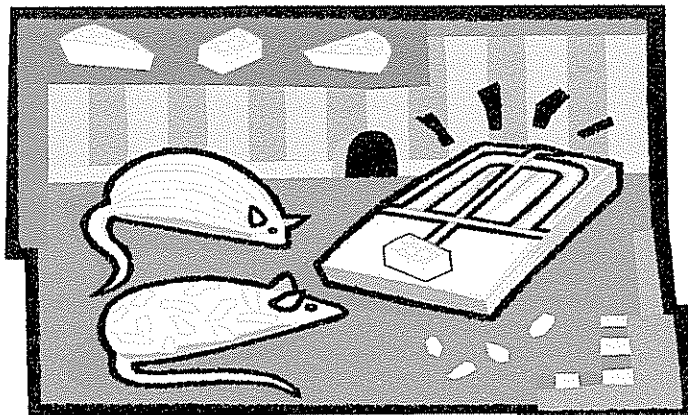

HOW ARE VOLUNTEERS SELECTED?

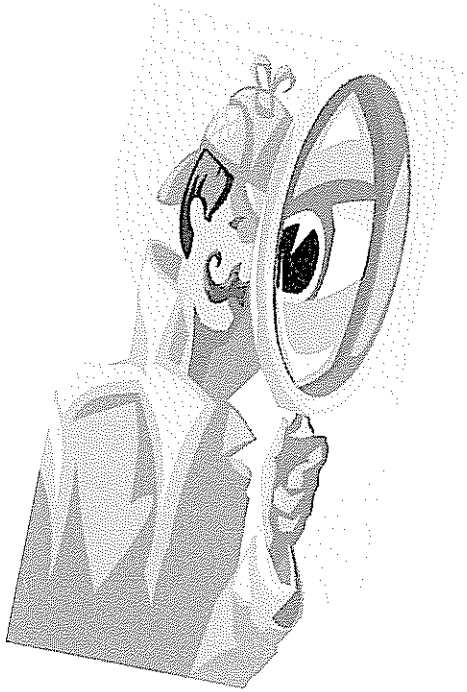

Prospective volunteers are initially informed of what the requirements are before they submit an application. Applications are screened and qualifying applicants are invited to an interview panel. Two things can happen at this point; a match of volunteer to position occurs or a second interview is set up with a prospective supervisor. When a match takes place, the candidate continues in the process. It is important that both the Department and the volunteer are happy with the arrangement.

Upon acceptance, a background check is conducted based upon an extensive ten-year history questionnaire. The background also includes checking warrants, checking with the DMV, filing fingerprints with DOJ and the FBI, and drug screening.

It is expected that volunteers will remain in their assignment for one year. Each volunteer verbally commits to a minimum of 200 hours service within the first year prior to their acceptance into the program. When they continue to be satisfied with the assignment and the Department is satisfied with their work, they can continue. However, it is not unusual for a volunteer to desire a change to something else. At that point, the Volunteer Coordinator will try to find another position for the volunteer and a replacement volunteer for the section they are leaving.

HOW LONG WILL IT TAKE TO GET A VOLUNTEER?



Finding the right volunteer for any given position can take time and there is no guarantee that the right volunteer will come along. However, the Volunteer Coordinator will make every effort to meet your needs. Past history has shown that we are able to fill requests within 1-2 weeks. We are always looking for good volunteers so please contribute to the recruiting process by referring people who want to get involved.

Volunteers enter the program just twice a year following a 2-week V.I.P.S. Training Academy. However, we are usually able to find volunteers for assignments at any time throughout the year because active volunteers are willing to take on additional responsibilities.

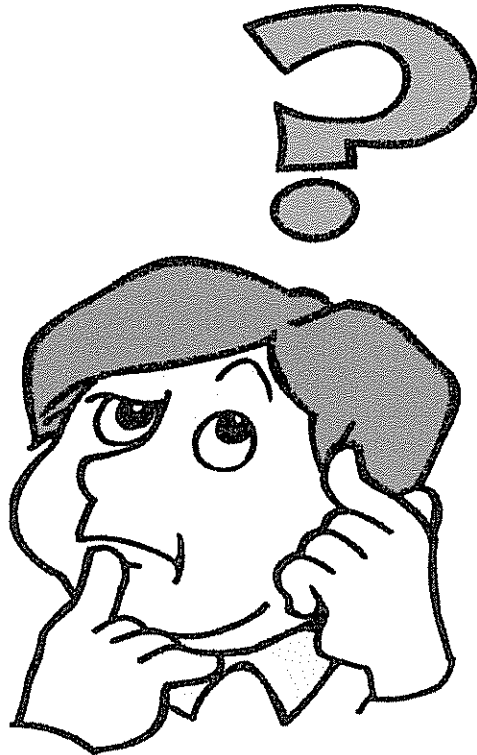

**OKAY, I'VE GOT A VOLUNTEER,
NOW WHAT DO I DO?**

Establish a work schedule with your new volunteer and set a start date as soon as possible. Long waits create doubts and uncertainty about being wanted and needed. On the first day welcome and introduce your volunteer to staff. Be sure the volunteer receives a tour of the office and knows where to find things. After acquainting the volunteer with the work setting, provide adequate work space and instruction for starting the job. Remember, initially even simple jobs can be confusing.

WHAT ARE MY RESPONSIBILITIES?



The most important thing to remember about working with volunteers is that you are the supervisor. Prior to the first day of work, each volunteer receives a handbook and training which outlines general Department policies, procedures and confidentiality requirements. However, as the volunteer's supervisor, you are expected to provide specific training and to orient the volunteer to your section. Just like any new staff member, the volunteer needs to "learn the ropes."

In addition, try to be available to offer assurance and to answer any questions that may come up. When you are not available, assign a back-up person to take on these responsibilities.



WHAT CAN I EXPECT FROM MY VOLUNTEER?

Volunteers know that they are held to the same standards as paid staff. Therefore, you should expect high-quality work and reliability. However, it is your responsibility to provide adequate training and supervision so that the volunteer has a chance to succeed. Volunteers want and expect an honest evaluation of their work. Be sure to talk to your volunteer about performance.



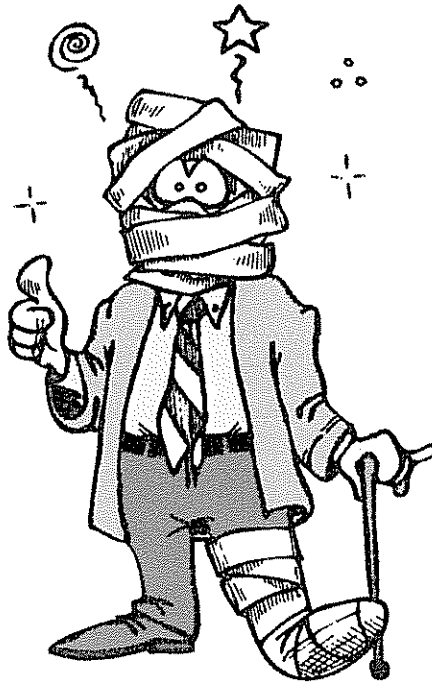

WHAT IF A VOLUNTEER GETS HURT?

Volunteers are covered for medical expenses by the City's self insurance for Workers' Compensation. The same accident and safety guidelines and procedures which apply to regular staff members also apply to volunteers. Of course, the utmost care should be taken to ensure that volunteers are not working in hazardous situations and have received instructions in the proper use of tools and equipment, lifting techniques, etc.

In the event that an accident does occur, it is your responsibility, as the supervisor, to document what happened. This should be done when any injury occurs—no matter how slight. As with paid employees, a supervisor incident report form should be completed. The volunteer should also provide a description by completing an incident report form. Please send a copy of both forms to the Volunteer Coordinator and Human Resources - Fax (707) 449-5353 - immediately. In the event the volunteer needs to get medical assistance, they should be provided with a Workers' Compensation claim form within 24 hours of the supervisor's knowledge of the need for medical care. Completed form should be submitted to Department H.R. Manager.

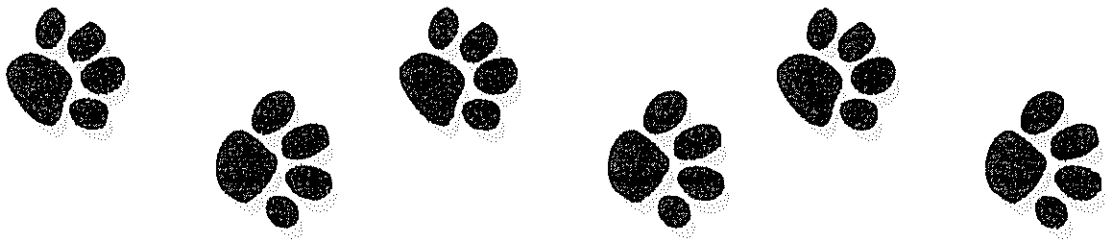

WHO KEEPS TRACK OF THE VOLUNTEER'S PROGRESS?

Tracking Folders

The volunteer's supervisor is given a yellow confidential tracking folder. The folder contains a picture, contact and emergency information, special skills and training, a place to record additional training, other locations the volunteer is assigned within the Department, a master to provide additional time sheets, a list of issued equipment, and a status report form.

Status Report Forms

The status report form does not take the place of verbal communication with the Coordinator, but it is a tool used to evaluate the success of the volunteer's placement and proficiency.

Return of the Tracking Folder

When a volunteer transfers to another Section or resigns, a status report form is to be completed and returned to the Coordinator along with the tracking folder.

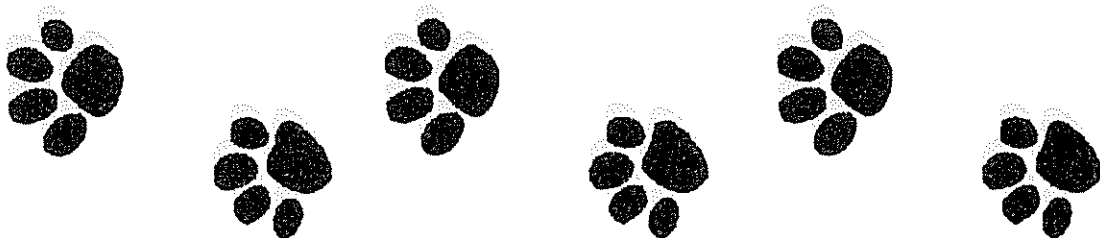

WHAT TRAINING HAS THE VOLUNTEER RECEIVED?

Policies and Procedures

Volunteers are trained in the Department's Policies and Procedures during their orientation. Each volunteer also reviews and is given a handbook that contains confidentiality policies and applicable General Orders.

CLETS Exposure

Volunteers receive a four hour mandatory CLETS training class for practitioners. A practitioner is every individual who works within an office where CLETS is in operation. This training is mandated by the Department of Justice. Prior to 2005, only volunteers who were assigned to an office where CLETS was in operation received the training. When in doubt about your volunteer's status, ask the Coordinator.

CLETS Data Entry and Retrieval

Individuals who access CLETS information or input into the system are required to attend the six hour CLETS training course. It is the supervisor's responsibility to make sure the volunteer has completed the course before allowing access. The Coordinator and Departmental CLETS Representative will both have this on file. The Coordinator will arrange the training upon request.

Mandatory Quarterly Training

Volunteers attend quarterly training meetings that are facilitated by the Coordinator. The topics vary according to need.

Job Specific Training

Volunteers vary in ability and knowledge. It is the responsibility of the supervisor to provide job specific training and oversight.



WHAT CAN VOLUNTEERS DO?

When there is a need and the environment is safe for civilians to work within, the possibilities are limitless. Below is a list of duties volunteers have assisted with in the past.

- **Administrative Assistance**
- **Background/Reference Checks**
- **Clerical Tasks**
- **Canvas Businesses & Neighborhoods**
- **Coordinate & Facilitate Events**
- **Counter Reports**
- **Create Newsletters**



- **Data Entry**
- **Design a Database**
- **DUI Check Point Assistance**
- **Livescan and Fingerprinting**
- **Lost Child/Adult Searches**
- **Mass Mailings**
- **Order Supplies**
- **Purge Files**

- **Research Information**
- **Telephone Calls**
- **Traffic Control at Accident Scenes**
- **Transport Vehicles**
- **Transport Interoffice Mail**
- **Web Research & Design**
- **Wellness Checks**
- **Vacation Checks**
- **Write Non-Moving Parking Citations**



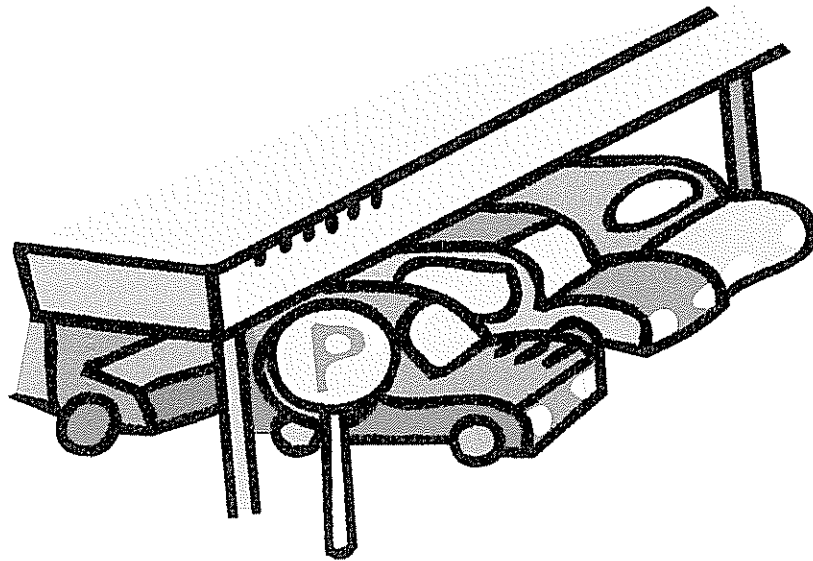

ARE VOLUNTEERS ALLOWED TO DRIVE A CITY VEHICLE?

The use of any City owned passenger motor vehicle by a volunteer for City business requires the prior approval of the Department Head. Use of any vehicle, other than a six-person or less passenger vehicle, is prohibited.

An “*Authorization for City Volunteer for Use of City Vehicle for City Business*” form must be on file with Risk Management. Most volunteers are on file. The supervisor must contact the Volunteer Coordinator to verify a form is on file before the volunteer is granted permission to drive.

All of the volunteer’s names are submitted to the Department of Motor Vehicles for participation in the DMV Pull Notice Program upon enlistment.

WHAT IF IT DOESN'T WORK OUT?

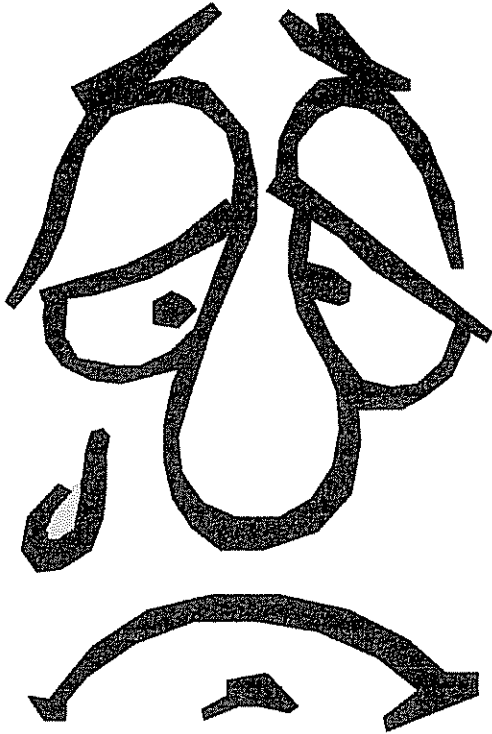

From time to time a volunteer may be placed in a position that is not suited to his or her personality or skill level. When your volunteer's work seems unsatisfactory, discuss your needs and expectations with the volunteer and suggest ways to improve. Most of the time, problems are due to a misunderstanding of instructions or agreements. If, after working with your volunteer, the problem persists, contact the Volunteer Coordinator for assistance. Don't wait until the problem becomes intolerable for you and the volunteer.

Removing the volunteer from a specific job is never an easy task but sometimes it's necessary. The Volunteer Coordinator will work with you to ensure that the situation is handled in a manner which would allow the volunteer to retain his or her self-esteem. Perhaps the volunteer can be placed in another position or referred to another agency.

HOW CAN I EVER THANK MY VOLUNTEER?

Recognition is important if you wish to retain your volunteer. Treat your volunteer as you wish to be treated. People, no matter who they are, want to feel needed and valued. Take time to express genuine interest in your volunteer. A smile, a word of praise, remembrance of special days, or a “thank you” can mean a great deal.

Volunteers are included in the Department’s Quarterly and Annual Awards. Take a few minutes when opportunities arise to nominate your volunteer. However, you can do much to make your volunteer feel good about their contribution on a more frequent basis by recognizing their efforts and letting them know how much you appreciate their assistance. Unlike paid staff, they are volunteers and work because they want to.

